



RF2F Reverse Node

At the end of almost every feeder line there are potential customers that could be fed with a system extension, but the cost is prohibitive. Utilizing our RF2F reverse node, fiber can be run off of your RF plant to serve customers up to 2 miles economically. The RF2F is available with a single, dual, quad or 8 outputs to easily and inexpensively extend your system. Simply add the RF2F unit in your feeder line, just as you would a regular tap, and then run fiber from the RF2F to your customers home. At the home install a [RFoG](#) mini-node and enjoy the added revenue of a happy customer.

Each RF2F can be configured with a single or dual 1550 transmitters, each with single outputs, or with 2-way or 4-way splits. For example the 8 way RF2F unit includes (2) High power (7dBm) 1550 nm transmitters, (2) 1310 or 1610 receivers, (2) WDM combiners and (2) 4-way fiber splitters giving it a total of 8 outputs. An internal AC power supply is also enclosed in the RF2F's small die cast housing. Dual transmitters and receivers are used to eliminate the requirement to use high power TEC laser diodes, which are costly and require extra circuitry to maintain thermal stability. In addition by using dual receivers, (each one only receiving only 4 inputs), the chance of OBI (Optical Beat Interference) is minimized.

RF2F 17dB EDFA is also available.

Part Number Matrix

RF2F- [x] - [x] - [x] TBBS

M = Mini Housing (RF input Powered)
AC= Wall Wort (AC Adaptor Powered)

15/13 = 1550nm forward transmitter and 1310nm return receiver
15/16 = 1550nm forward transmitter and 1610nm return receiver



Fiber Outputs and FWD Transmitter Output Power (OP)

- 1/3 = Single fiber output with standard 3dBm transmitter OP
- 1/7 = Single fiber output with standard 7dBm transmitter OP
- 2/0 = Dual fiber outputs with 0dBm transmitter OP (each port)
- 2/3 = Dual fiber output with standard 3dBm transmitter OP (each port)
- 4/0 = Quad fiber outputs with 0dBm OP (each port)
- 4/3 = Quad fiber outputs with 3dBm OP (each port)
- 8/0 = Eight fiber outputs with 0dBm OP (each port)



Category Reverse Nodes



Features

- Dual Power Surge arresters installed
- Uses industry standard JXP pads and Equalizers
- Output power test port (1v=1mW)
- Power status LED
- Return Level Test Port: Return input level monitoring, -20dB test point.
- Output Level Test Port: Forward output level monitoring, -20dB monitoring test point.
- Forward and Return Optical Input Port: Connect to bi-directional fiber with SC/APC connector
- Receiving Optical Power Indicator: If the optical receive power is normal, LED is green, if low LED is red.

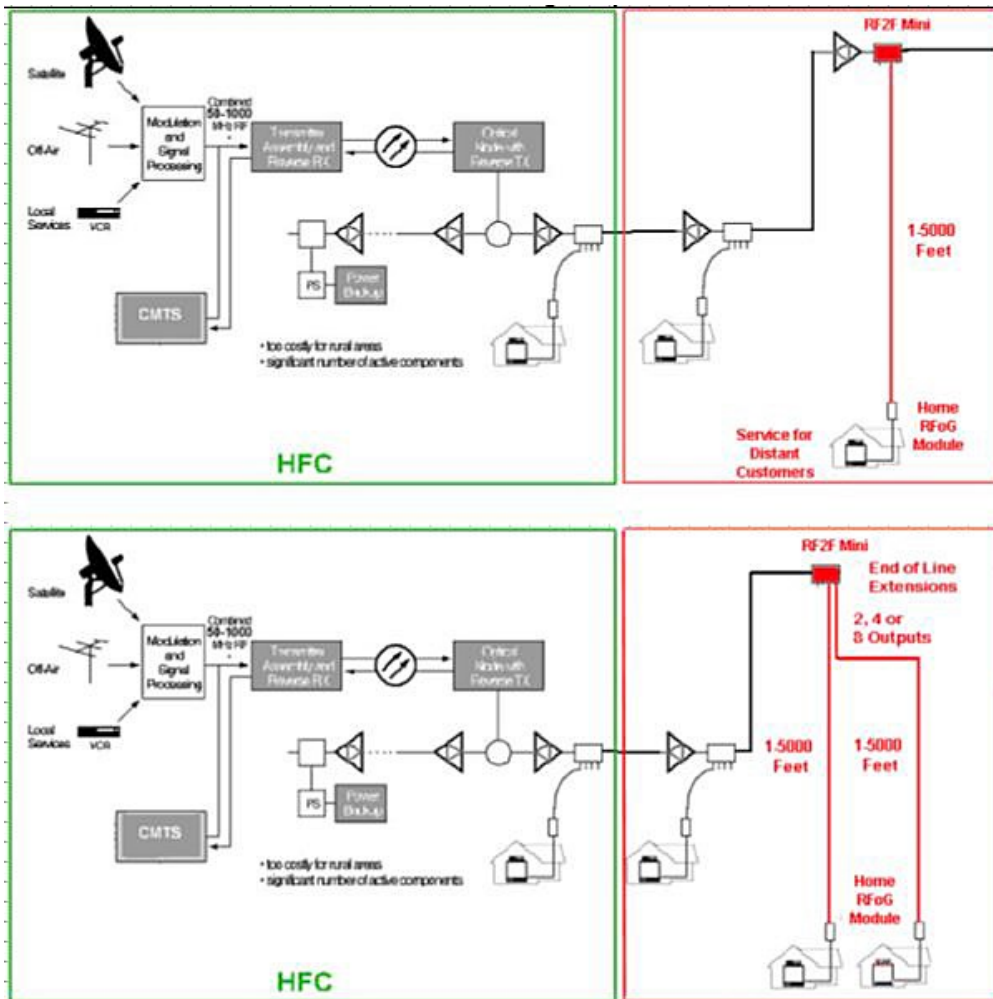



Category Reverse Nodes



Specifications

Parameter		Value	Option
Optic Specs	Wavelength	(nm)	1548~1563
	Line width	(MHz)	≤1
	Side mode suppression ratio	(dB)	≥45
	Extinction ratio	(dB)	≥20
	Equivalent noise intensity	(dB/Hz)	≤-160
	Output power	(dBm)	7
	Return loss	(dB)	≥55
	Optical fiber connector		SC/APC
RF Specs	Bandwidth	(MHz)	45-1210
	Input level	(dBmV)	10
	Flatness	(dB)	≤±1.5
	Return loss	(dB)	>16
	Noise Figure	(dB)	8
	Input impedance	(Ω)	75
Link Specs	Transmit channel loading		NTSC/78CH
	CNR	(dB)	≥50
	CNR	(dB)	≥48
	CTB	(dBc)	60
	CSO	(dBc)	60
	Power supply	(V)	40-90 VAC
	Power	(W)	≤2
	Work temp.	(C)	-40 ~ +65
	Storage temp.	(V)	-40~ 85
	Operating relative humidity	(%)	5~95
	Size	(")	7.5×10×4
OPTIONS: <ul style="list-style-type: none"> • 1310nm or 1610nm return • Single, Dual or Quad Internal Optical Splitters 			



Set-up Procedure

The RF2F is fed from the Cable System’s RF subscriber feeder line (hard line with Signal and AC). It is fed from a splitter, dc-coupler or off the end of a tap line. The RF2F feeds a fiber drop to the subscriber’s home where a RFoG micro node is installed.

Install the RF2F

- The minimum signal required for the RF2F is 10dBm.
- The minimum AC voltage required is 40V.
- The RF2F requires a **FLAT** input. A selection of JXP pads and cable simulators are needed for setup.

- ⇒ Measure the low channel forward RF signal at input test port. (1) **Note: test port is 20dB down!**
- ⇒ Pad the low channel at input JXP pad socket until it reads +10dB. (2) **Note: test port is 20dB down!**
- ⇒ Now measure the high channel, then subtract the low channel reading of 10dB from it. This will help determine what value cable simulator needed to flatten the input to the RF2F. (Example: High channel reads 17dB so, 17-10=7dB. A 7dB cable simulator is needed.)
- ⇒ Add the correct value cable simulator to second JXP socket (3) **Note: You may need to repeat the pad and EQ steps again to get the desired flat 10dB level.**

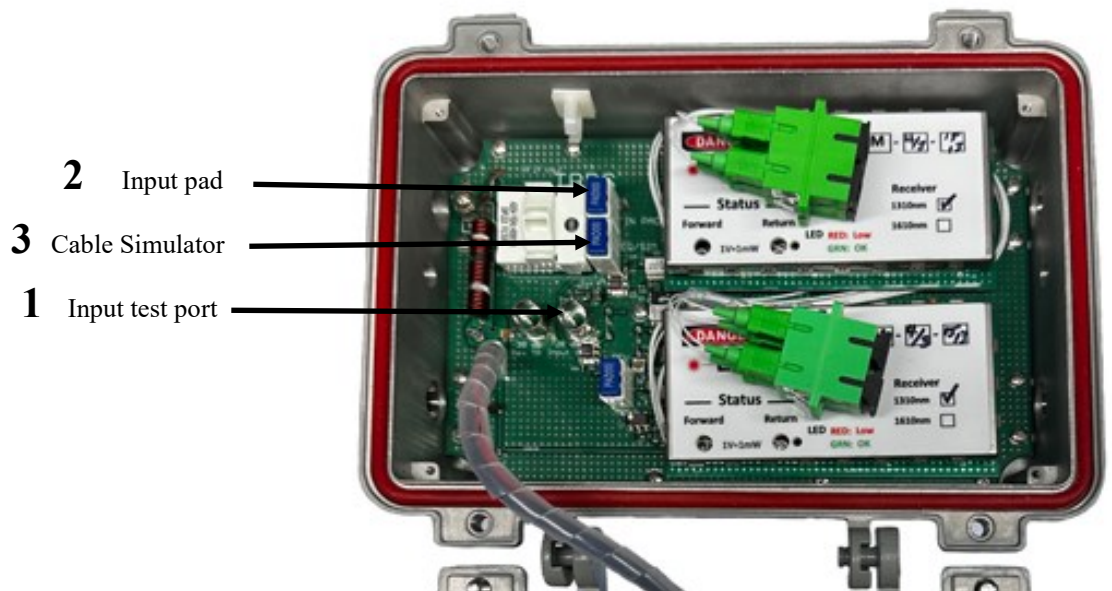



Set-up Procedure cont.

Install the RFoG:

- A RFoG micro Node is required for each subscriber.
- The Installed RFoG CWDM must match the RF2F. Example, a RF2F –M-1/3-15/13 must be coupled with a RFoG 1550/1310 micro node.
- The minimum recommended forward 1550nm optical level hitting the RFoG is: - 4dBm digital, -2dBm for analog
- The longest recommended fiber run is 10,000 feet, (3km).

⇒ Measure the optical level at the RFoG location. Make sure you are within specifications.

⇒ Connect the fiber drop and power drop into the RFoG. The LED should turn Green.

Return to the RF2F:

⇒ The optical return LED should now be green. If not, check levels and connections.

⇒ Measure the Return RF level at the return test port. (1) **Note: test port is 20dB down!**

⇒ Attenuate the return RF level with JXP pad as needed. (2)

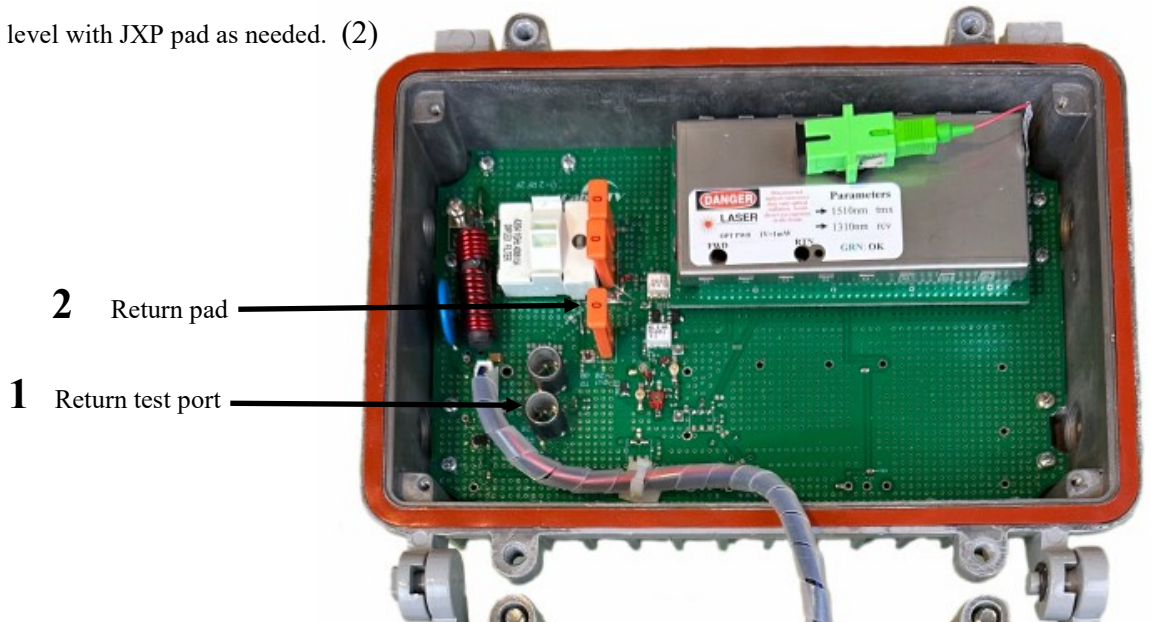



Category Reverse Nodes



Accessories

Attenuator Pads



Part Number	Description
PDLC-P00TBBS	Pad 1.2GHz, JXP, 0.7" Tall, PDLC, Pad, 0 dB
PDLC-P01TBBS	Pad 1.2GHz, JXP, 0.7" Tall, PDLC, Pad, 1 dB
PDLC-P02TBBS	Pad 1.2GHz, JXP, 0.7" Tall, PDLC, Pad, 2 dB
PDLC-P03TBBS	Pad 1.2GHz, JXP, 0.7" Tall, PDLC, Pad, 3 dB
PDLC-P04TBBS	Pad 1.2GHz, JXP, 0.7" Tall, PDLC, Pad, 4 dB
PDLC-P05TBBS	Pad 1.2GHz, JXP, 0.7" Tall, PDLC, Pad, 5 dB
PDLC-P06TBBS	Pad 1.2GHz, JXP, 0.7" Tall, PDLC, Pad, 6 dB
PDLC-P07TBBS	Pad 1.2GHz, JXP, 0.7" Tall, PDLC, Pad, 7 dB
PDLC-P08TBBS	Pad 1.2GHz, JXP, 0.7" Tall, PDLC, Pad, 8 dB
PDLC-P09TBBS	Pad 1.2GHz, JXP, 0.7" Tall, PDLC, Pad, 9 dB
PDLC-P10TBBS	Pad 1.2GHz, JXP, 0.7" Tall, PDLC, Pad, 10 dB
PDLC-P11TBBS	Pad 1.2GHz, JXP, 0.7" Tall, PDLC, Pad, 11 dB
PDLC-P12TBBS	Pad 1.2GHz, JXP, 0.7" Tall, PDLC, Pad, 12 dB
PDLC-P13TBBS	Pad 1.2GHz, JXP, 0.7" Tall, PDLC, Pad, 13 dB
PDLC-P14TBBS	Pad 1.2GHz, JXP, 0.7" Tall, PDLC, Pad, 14 dB
PDLC-P15TBBS	Pad 1.2GHz, JXP, 0.7" Tall, PDLC, Pad, 15 dB
PDLC-P16TBBS	Pad 1.2GHz, JXP, 0.7" Tall, PDLC, Pad, 16 dB
PDLC-P17TBBS	Pad 1.2GHz, JXP, 0.7" Tall, PDLC, Pad, 17 dB
PDLC-P18TBBS	Pad 1.2GHz, JXP, 0.7" Tall, PDLC, Pad, 18 dB
PDLC-P19TBBS	Pad 1.2GHz, JXP, 0.7" Tall, PDLC, Pad, 19 dB
PDLC-P20TBBS	Pad 1.2GHz, JXP, 0.7" Tall, PDLC, Pad, 20 dB



Category Reverse Nodes



Accessories

Cable Simulators



Part Number	Description
PDLC-1G-CS02TBBS	Cable Simulator, 1.2GHz JXP, 0.7" Tall, PDLC, Cable Simulator, 2 dB
PDLC-1G-CS03TBBS	Cable Simulator, 1.2GHz JXP, 0.7" Tall, PDLC, Cable Simulator, 3 dB
PDLC-1G-CS04TBBS	Cable Simulator, 1.2GHz JXP, 0.7" Tall, PDLC, Cable Simulator, 4 dB
PDLC-1G-CS05TBBS	Cable Simulator, 1.2GHz JXP, 0.7" Tall, PDLC, Cable Simulator, 5 dB
PDLC-1G-CS06TBBS	Cable Simulator, 1.2GHz JXP, 0.7" Tall, PDLC, Cable Simulator, 6 dB
PDLC-1G-CS07TBBS	Cable Simulator, 1.2GHz JXP, 0.7" Tall, PDLC, Cable Simulator, 7 dB
PDLC-1G-CS08TBBS	Cable Simulator, 1.2GHz JXP, 0.7" Tall, PDLC, Cable Simulator, 8 dB
PDLC-1G-CS09TBBS	Cable Simulator, 1.2GHz JXP, 0.7" Tall, PDLC, Cable Simulator, 9 dB
PDLC-1G-CS010TBBS	Cable Simulator, 1.2GHz JXP, 0.7" Tall, PDLC, Cable Simulator, 10 dB
PDLC-1G-CS011TBBS	Cable Simulator, 1.2GHz JXP, 0.7" Tall, PDLC, Cable Simulator, 11 dB
PDLC-1G-CS12TBBS	Cable Simulator, 1.2GHz JXP, 0.7" Tall, PDLC, Cable Simulator, 12 dB
PDLC-1G-CS13TBBS	Cable Simulator, 1.2GHz JXP, 0.7" Tall, PDLC, Cable Simulator, 13 dB
PDLC-1G-CS14TBBS	Cable Simulator, 1.2GHz JXP, 0.7" Tall, PDLC, Cable Simulator, 14 dB
PDLC-1G-CS15TBBS	Cable Simulator, 1.2GHz JXP, 0.7" Tall, PDLC, Cable Simulator, 15 dB
PDLC-1G-CS16TBBS	Cable Simulator, 1.2GHz JXP, 0.7" Tall, PDLC, Cable Simulator, 16 dB



Category Reverse Nodes



Accessories

Forward Equalizers



Part Number	Description
PDLC-1GHz-EQ02TBBS	EQ Fwd, 1GHz JXP, 0.7" Tall, PDLC, Forward Equalizer, 2 dB
PDLC-1GHz-EQ04TBBS	EQ Fwd, 1GHz JXP, 0.7" Tall, PDLC, Forward Equalizer, 4 dB
PDLC-1GHz-EQ06TBBS	EQ Fwd, 1GHz JXP, 0.7" Tall, PDLC, Forward Equalizer, 6 dB
PDLC-1GHz-EQ08TBBS	EQ Fwd, 1GHz JXP, 0.7" Tall, PDLC, Forward Equalizer, 8 dB
PDLC-1GHz-EQ10TBBS	EQ Fwd, 1GHz JXP, 0.7" Tall, PDLC, Forward Equalizer, 10 dB
PDLC-1GHz-EQ12TBBS	EQ Fwd, 1GHz JXP, 0.7" Tall, PDLC, Forward Equalizer, 12 dB
PDLC-1GHz-EQ14TBBS	EQ Fwd, 1GHz JXP, 0.7" Tall, PDLC, Forward Equalizer, 14 dB
PDLC-1GHz-EQ16TBBS	EQ Fwd, 1GHz JXP, 0.7" Tall, PDLC, Forward Equalizer, 16 dB
PDLC-1GHz-EQ18TBBS	EQ Fwd, 1GHz JXP, 0.7" Tall, PDLC, Forward Equalizer, 18 dB
PDLC-1GHz-EQ20TBBS	EQ Fwd, 1GHz JXP, 0.7" Tall, PDLC, Forward Equalizer, 20 dB
PDLC-1GHz-EQ22TBBS	EQ Fwd, 1GHz JXP, 0.7" Tall, PDLC, Forward Equalizer, 22 dB



Part Number	Description
RF2F-Setup-Kit	RF2F Pad and Cable Simulator set-up kit, includes: 3,4,5,6,7,8,9,10dB pad/Attenuator and 8,9,10,11,12dB Cable Simulators